

**Fisa B1 cu detalii de proiectare si executie pentru
PODURI RUTIERE SI FERROVIARE**

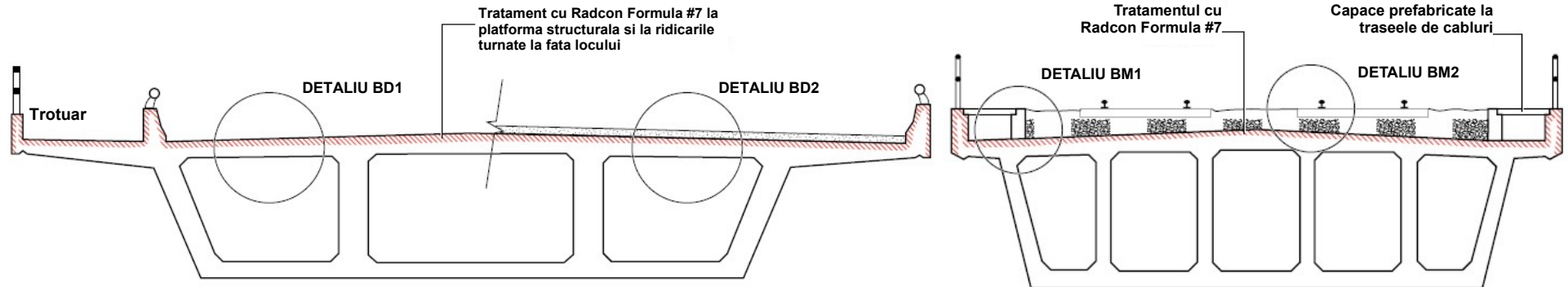

EXPRESS INTEGRATOR S.R.L.
Str. Baladei nr. 3, Bl. 61, Sector 4, Bucuresti
Mobil: 0723.23.77.10
Tel/fax: (021) 331.02.06
hidroizolatii@afacereamea.ro
www.hidroizolatii.afacereamea.ro



SECTIUNE TIPICA PRINTR-UN POD RUTIER

SECTIUNE TIPICA PRINTR-UN POD FERROVIAR

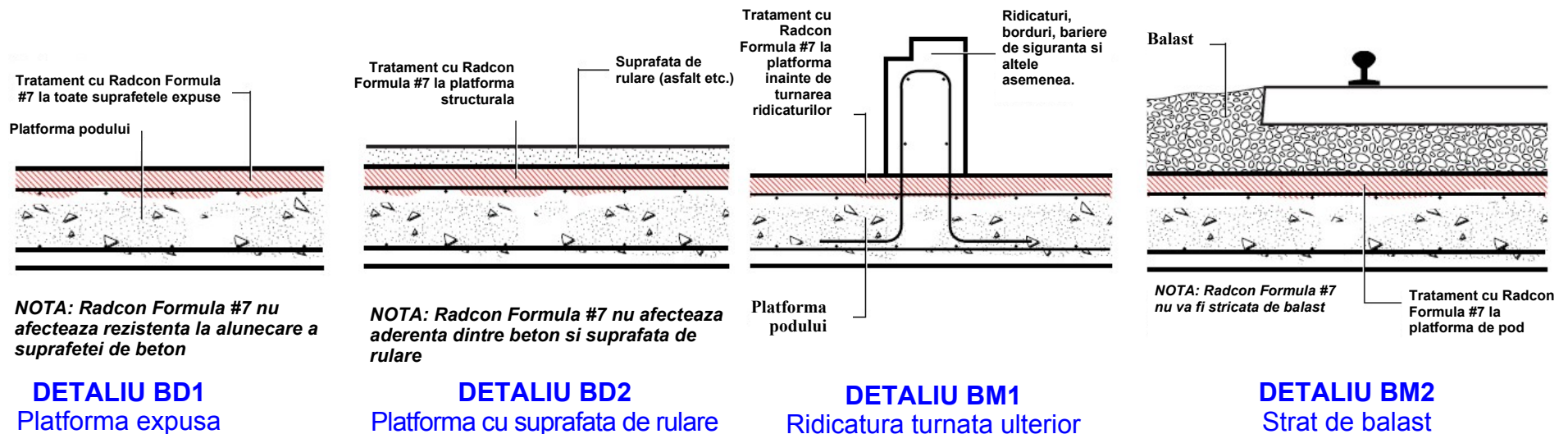

NOTA: Radcon Formula #7 nu afecteaza rezistenta la alunecare a suprafetei de beton

NOTA: Radcon Formula #7 nu afecteaza aderenta dintre beton si suprafata de rulare

NOTA: Radcon Formula #7 nu va fi stricata de balast

DETALIU BD1
Platforma expusa

DETALIU BD2
Platforma cu suprafata de rulare

DETALIU BM1
Ridicatura turnata ulterior

DETALIU BM2
Strat de balast